



SKATE TRAINER INSTRUCTIONS

PARTS INCLUDED



8 x 24" Tubes



4 x "T" fittings



4 x "Elbow" fittings

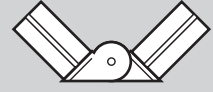

2 x Hinge fittings

ASSEMBLY

1

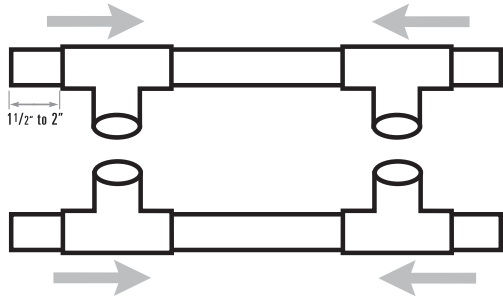

Slide two of the "T" fittings on each end of one of the 24" tubes leaving a 1 1/2" to 2" gap at each end.
Repeat with remaining two "T" fittings and one of the 24" tubes.

2

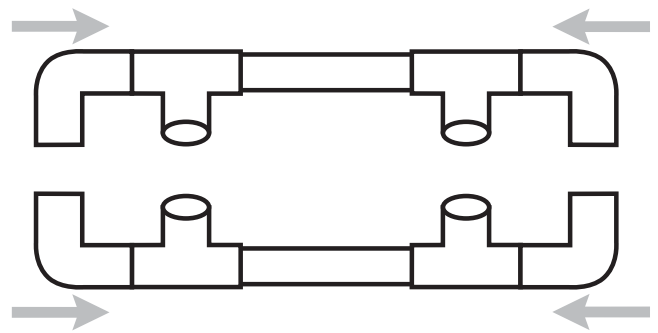

Slide the four "Elbow" fittings on each end of the 24" tubes.

3

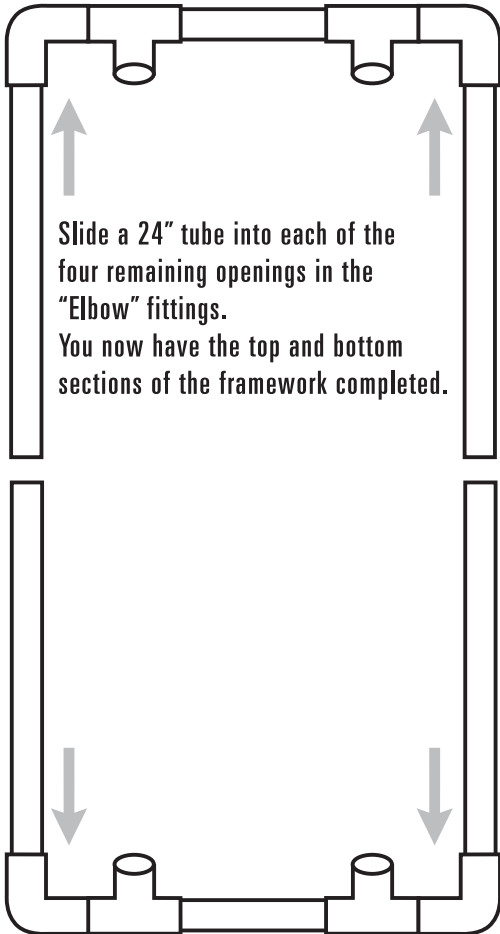

Slide a 24" tube into each of the four remaining openings in the "Elbow" fittings.
You now have the top and bottom sections of the framework completed.

4

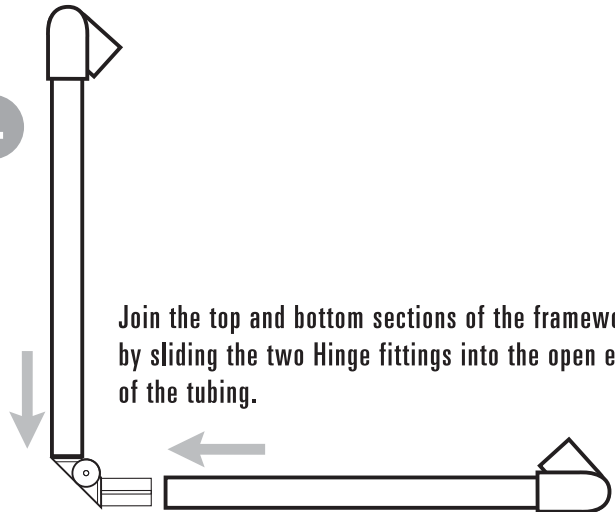

Join the top and bottom sections of the framework by sliding the two Hinge fittings into the open ends of the tubing.

5

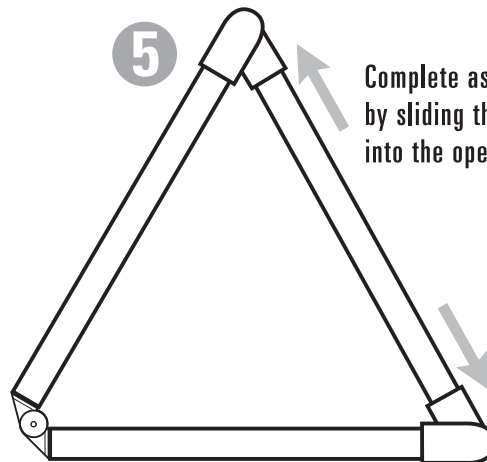

Complete assembly of the Skate Trainer by sliding the two remaining 24" tubes into the open ends of the "T" fittings.

To fold the Skate Trainer for easy transport or storage, simply slide the two 24" tubes out of the bottom two "T" fittings and the unit will easily collapse to a flat position.

PLEASE NOTE The Skate Trainer does NOT protect against possible injury due to the nature of ice skating. Approved head protection must be worn. Wrist, elbow and knee protection is also recommended. The Skate Trainer should never be used without adult supervision. Always check that the assembly of the Skate Trainer remains secure before each use.



DIRECTIVES DE
MONTAGE DU

SUPPORT À PATINEUR

PIÈCES COMPRISES



8 tubes de 24"



4 raccords en T



4 raccords coudés

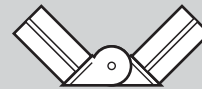

2 ferrures d'articulation

MONTAGE

1

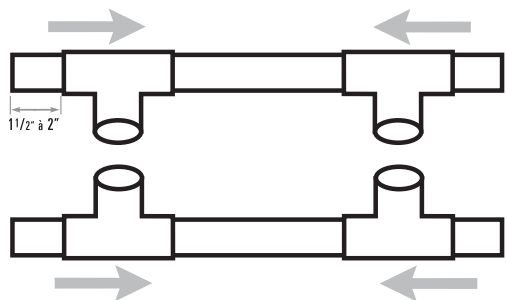

Insérer 2 raccords en T sur chaque extrémité d'un tube de 24" en laissant un espace de 1 1/2" à 2" à chaque extrémité. Répéter cette étape avec un autre tube de 24".

2

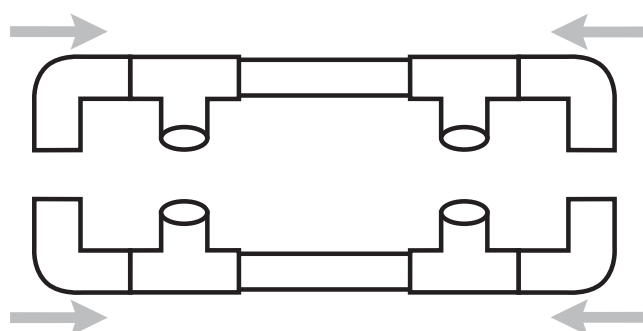

Insérer les 4 raccords coudés à chaque extrémité de ces 2 tubes de 24".

3

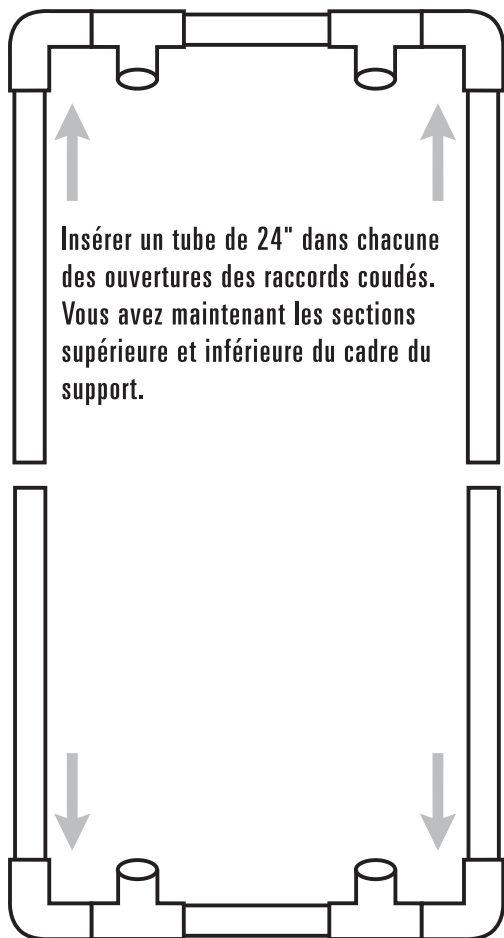

Insérer un tube de 24" dans chacune des ouvertures des raccords coudés. Vous avez maintenant les sections supérieure et inférieure du cadre du support.

4

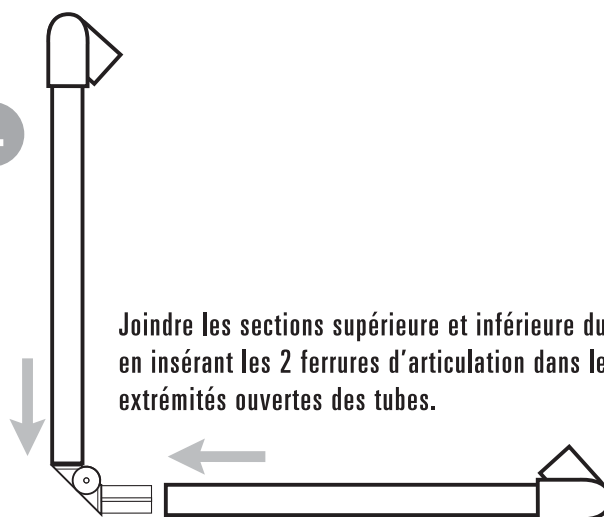

Joindre les sections supérieure et inférieure du cadre en insérant les 2 ferrures d'articulation dans les extrémités ouvertes des tubes.

5

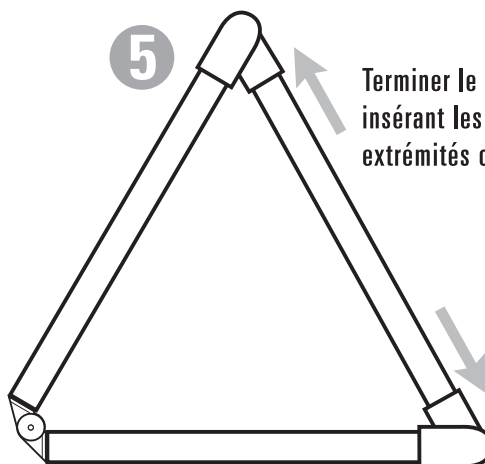

Terminer le montage du support à patineur en insérant les 2 derniers tubes de 24" dans les extrémités ouvertes des raccords en T.

Pour plier le support à patineur

afin de le transporter ou de l'entreposer, simplement enlever les 2 tubes de 24" des 2 raccords en T inférieurs et le support se repliera facilement à plat.

REMARQUE

Le support à patineur ne fournit PAS une protection contre les blessures pouvant être subies en patinant. Le patineur doit porter un casque protecteur approuvé et le port d'équipement pour protéger les poignets, les coudes et les genoux est également recommandé. Le support à patineur ne devrait jamais être utilisé sans la supervision d'un adulte. Vérifier que le support est bien monté avant chaque utilisation.